

Wheel Bearing, Front, Replace

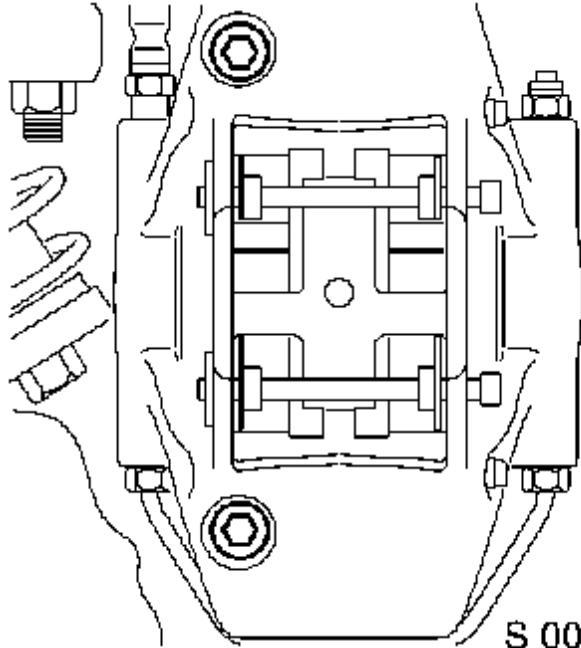

Remove

1. Chock rear road wheels
2. Raise and support vehicle
3. Remove front road wheel
 - Remove 4x bolt, remove security bolt
 - Use special socket located under front bonnet
4. Remove brake caliper assembly from wheel carrier
 - Remove 2x bolt



5. For earlier type wheel hub, remove brake disc
 - Remove screw

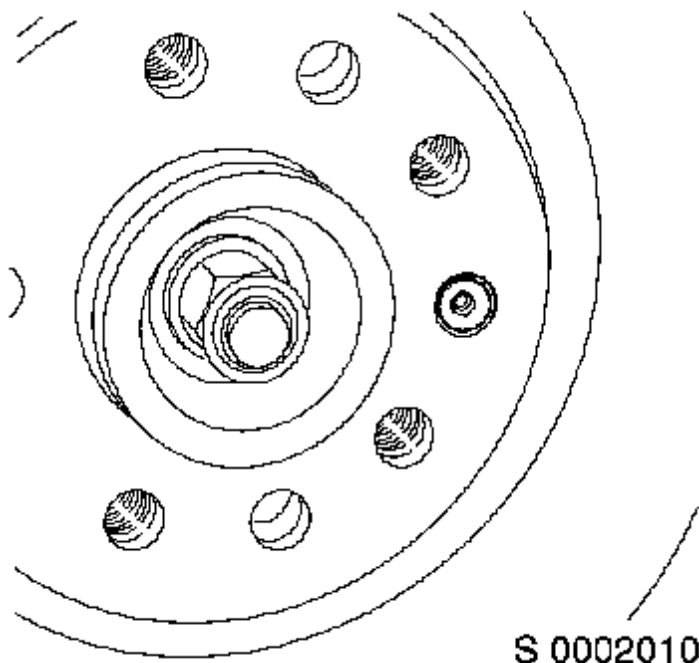

6. For later type wheel hub, remove brake disc
- Remove screw

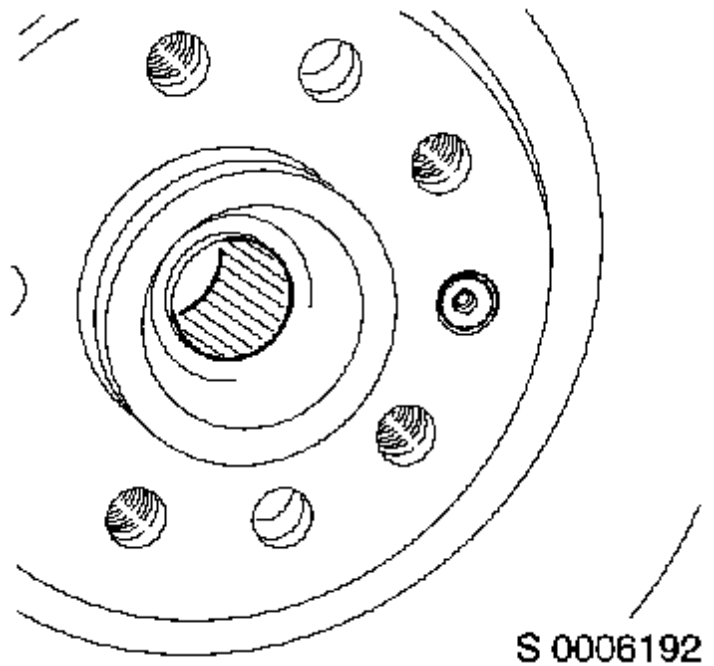

7. Release harness connector from wheel speed sensor
- Release clip

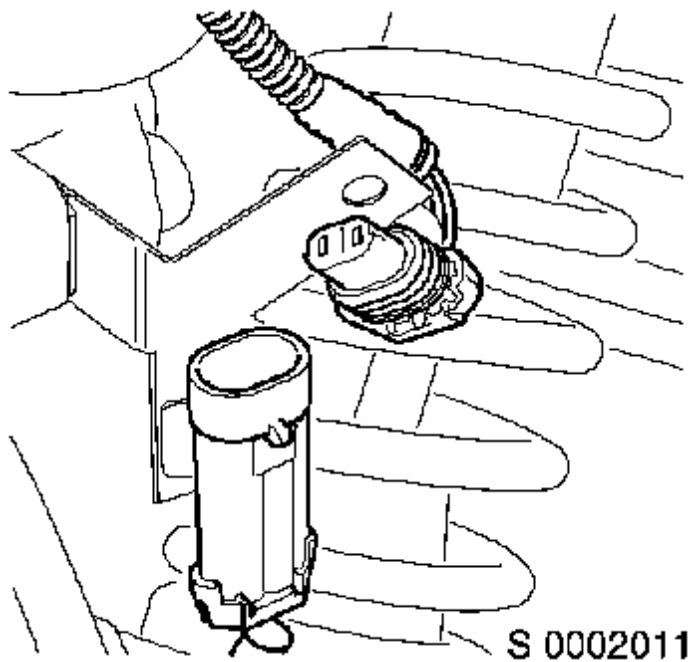

8. For earlier type wheel hub assembly, remove from hub carrier
- Note:** Wheel bearing part of hub assembly.
- Remove centre bolt, 4x washer, nut
 - Remove 3x bolt, 3x washer

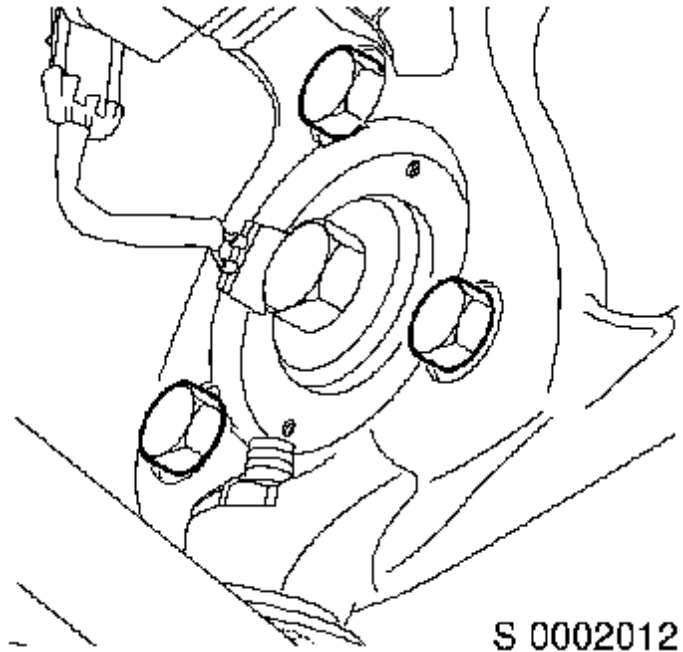

S 0002012

9. For later type wheel hub assembly, remove from hub carrier

Note: Wheel bearing part of hub assembly.

- Remove 3x bolt, 3x washer

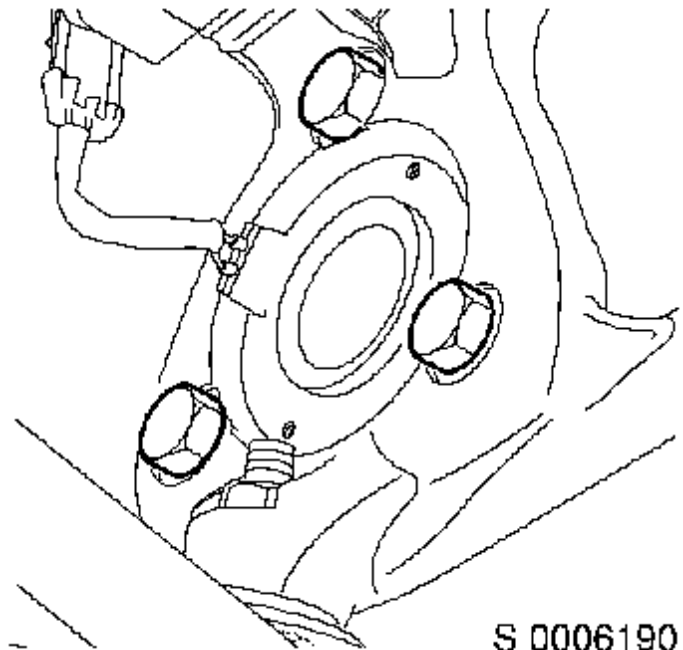

S 0006190



Install

10. Install wheel hub assembly to hub carrier
Note: Wheel bearing part of hub assembly.
 - Install 3x washer, 3x bolt **90 Nm**
11. For earlier type wheel hub, install centre bolt, 4x washer, nut **45 Nm**
12. Secure harness connector to wheel speed sensor
 - Secure clip
13. Install brake disc to wheel hub
 - Install screw

14. Install brake caliper assembly to hub carrier
 - Install 2x bolt **45 Nm**
 - Note:** Clean threads and apply locking compound.
15. Install front road wheel
 - Install 4x bolt, security bolt **90 Nm**
16. Raise vehicle and remove support
17. Lower vehicle
18. Remove chocks from rear road wheels